

OxyLift™

JAEGER-AERATION™

Innovative and Efficient System Design

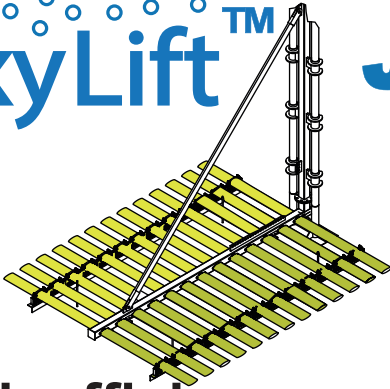

Multi-level aeration system redundancy  
 Highest SOTE % efficiency over the widest flux rate range  
 Organic loading optimization driven, retrofits & upgrades

## High efficiency retrievable strip diffuser rack system

### Wall-Mounted Rail Retrieval



Retrofit Rotor Ditch - 5 retrievable OxyStrip racks

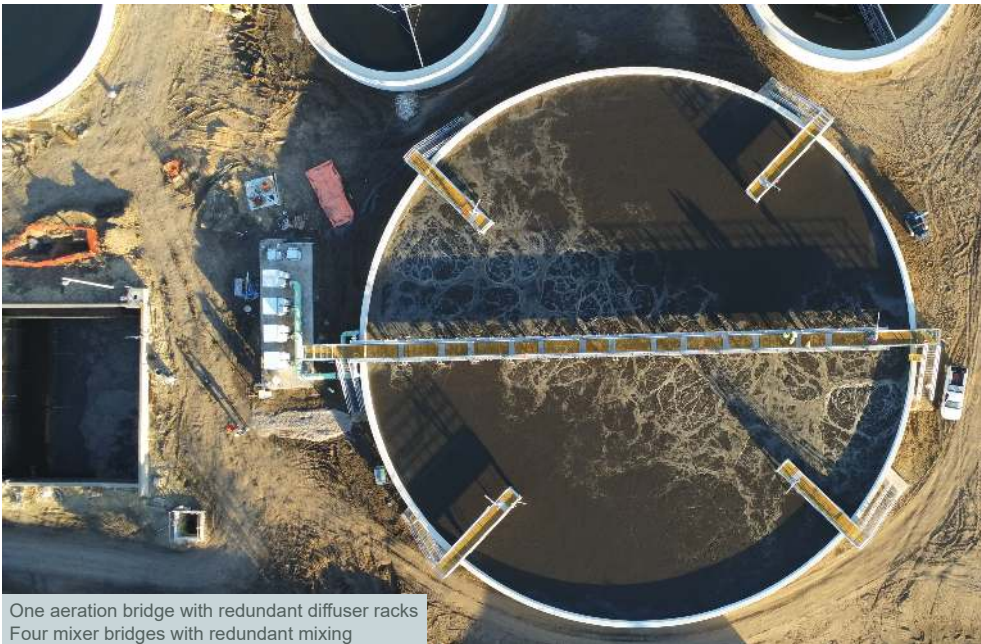

One aeration bridge with redundant diffuser racks  
 Four mixer bridges with redundant mixing

### Bridge or Walkway Access

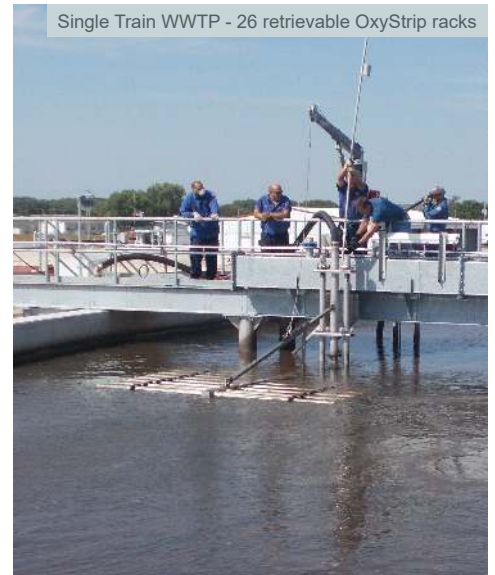

Single Train WWTP - 26 retrievable OxyStrip racks

#### Retrievable rack

- Multi-level system redundancy
- One OxyLift diffuser rack = 162 9" disc diffusers

#### Diffuser rack retrieval in 2 minutes

- Rack transfer system for diffuser maintenance
- Movable host and transfer system

#### No retrievability limitation by basin geometry

- Rectangular, round, toroidal, and square
  - Bridge or wall mounted
- OxyProcess compatible design

# OxyLift™ - 12 pair OxyStrip™ Retrievable Rack - Design Airflow & SOTE Range

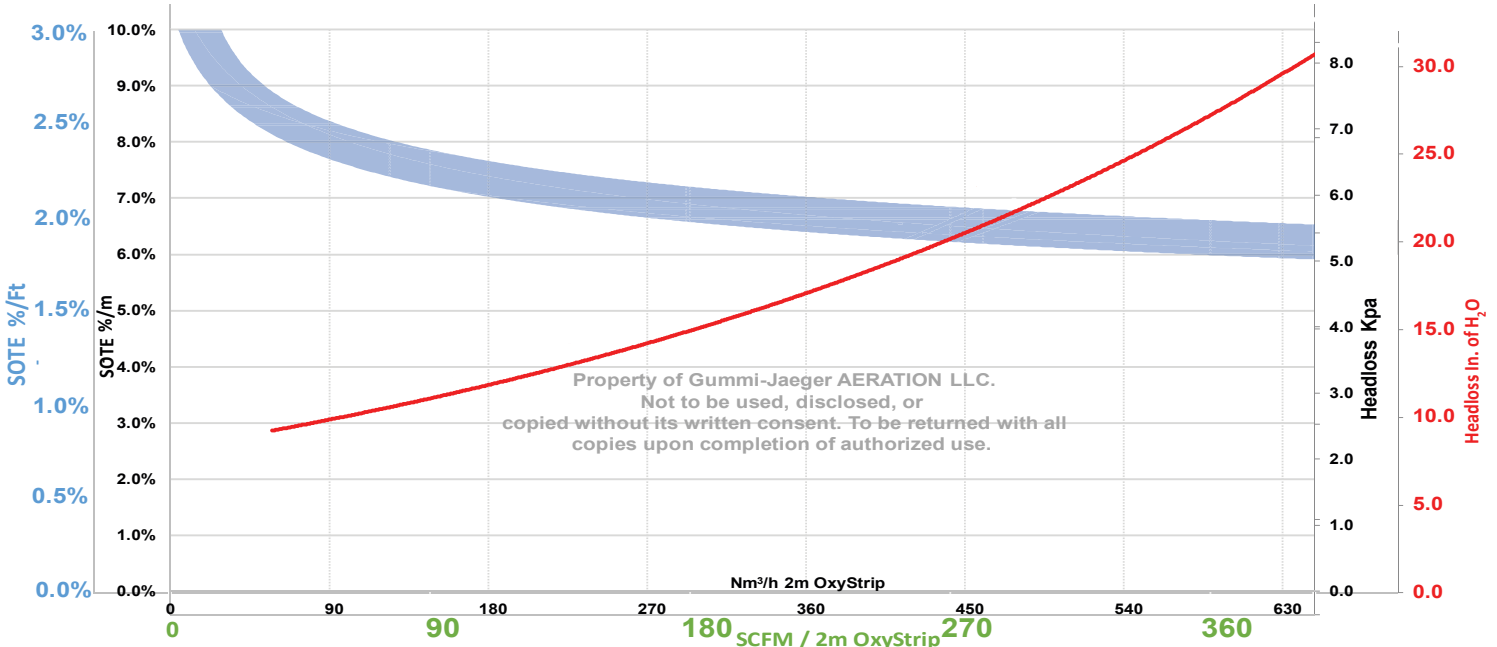

SOTE curves for reference only and benchmark SOTE test comparing JAEGER Oxy<sup>\*\*\*</sup>™ diffusers to select competitors' models are available on special request. SOTE is subject to tank geometry, diffuser insertion depth, diffuser density and other factors.

## OxyLift- 12 pairs of 1.5m OxyStrip diffusers - 8:1 System Turn Down:

### Airflow range

- 48 SCFM to 384 SCFM
- 72 Nm<sup>3</sup>/h to 616 Nm<sup>3</sup>/h

### Design

- 70 SCFM to 260 SCFM
- 120 Nm<sup>3</sup>/h to 420 Nm<sup>3</sup>/h

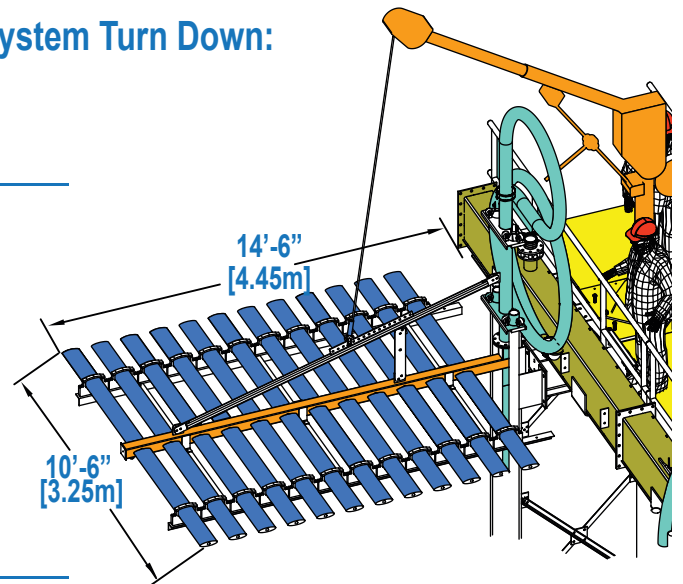

## Scope of supply OxyLift retrievable rack system:

- Diffusers system – fixed grid, retrievable, or retrievable bridge mounted
- Bridge with integrated air duct, diffuser rack transfer cart, & movable crane system
- Blower package; Blower air manifold; VFD Blower control cabinet
- Dissolved Oxygen and ORP (Oxidation Reduction Potential) control for process management
- Low speed submerged & retrievable misers
- VFD mixer motor control
- SCADA System
- Installation support & start up services

For more information, please contact your regional sales representative or get in touch with us directly:

**JAEGER AERATION LLC**  
4175 MULLIGAN DRIVE  
LONGMONT, CO 80504 - USA



**WWW.JAEGER-AERATION.COM**  
PHONE: +1 (970) 535-0554  
FAX: +1 (970) 535-0945  
INFO@JAEGER-AERATION.COM